

Pivot Sliding Door

For Door Size : 600-750mm* (W) x 1990-2200/2200 - 2700mm (H)

Single Leaf Pivot Sliding Door (Max 30/50kg)

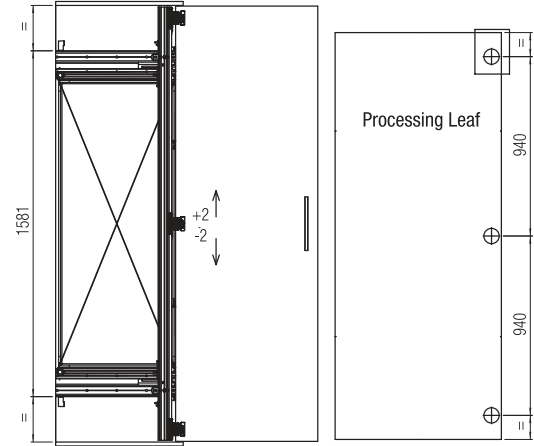
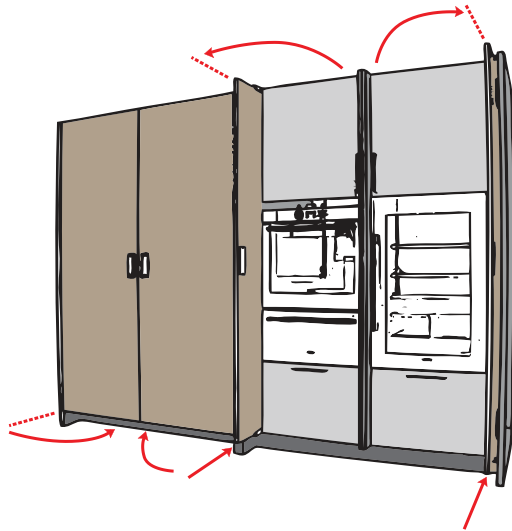

Item Code	Item Description
49.9500.1.560	Single Leaf Pivot Sliding Door 1990 - 2200mm, 30kg
49.9500.2.560	Single Leaf Pivot Sliding Door 2200 - 2700mm, 50kg
49.9500.1.665	Single Leaf Pivot Sliding Door 1990 - 2200mm, 30kg
49.9500.2.665	Single Leaf Pivot Sliding Door 2200 - 2700mm, 50kg
49.9500.1.750	Single Leaf Pivot Sliding PB765 1900-2200mm, 3 hinge, 30kg

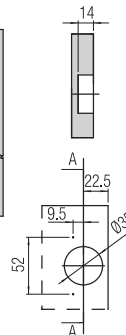
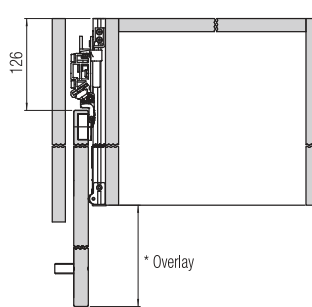
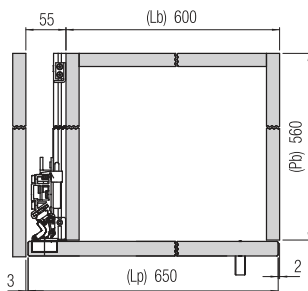

* Reversible system

Note : (Lp) 650-(Pb)665+126 = Door Overlay

Hp= Panel Height (1990-2200 / 2200-2700 mm)
Sp= Panel thickness (18-30 mm)
Lp= Panel Width
Pb= Panel Depth
Lb= Box Width

Leaf inside the box

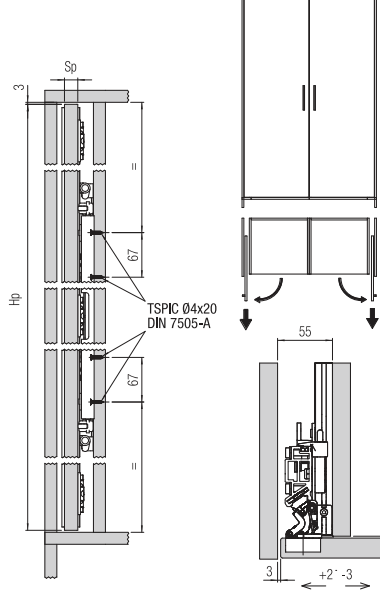

Suitable used in:
- Walk in closet
- Kitchen Monoblock
- Laundry room of the house

Leaf build into the wall cavity

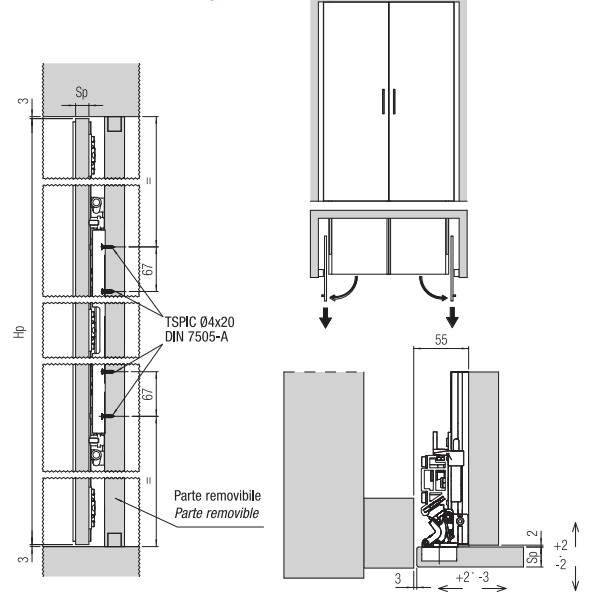

Pivot Sliding Door

Double Leaf Pivot Sliding Door (Max 30- 60kg)

2 Panel Max 30kg for door size : 600-650*mm(W) x 1200-1400mm (H)

2 Panel Max 60kg for door size : 600*(W) x 1900-2200 / 2200-2700mm (H)

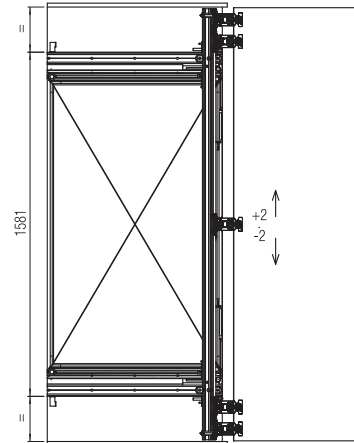
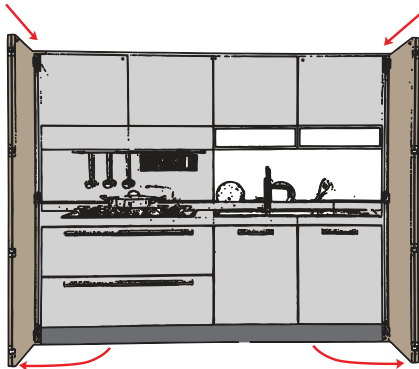

Item Code	Item Description
49.9500.1.805	Double Leaf Pivot Sliding Door 1990 - 2200mm, 60kg
49.9500.2.805	Double Leaf Pivot Sliding Door 2200 - 2700mm, 60kg
49.9500.3.805	Double Leaf Pivot Sliding Door 1200 - 1400mm, 30kg

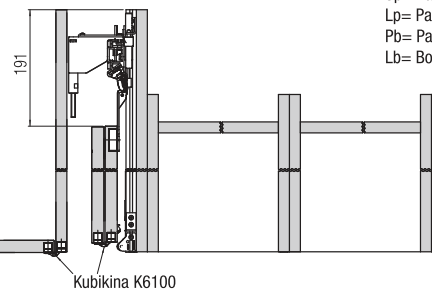
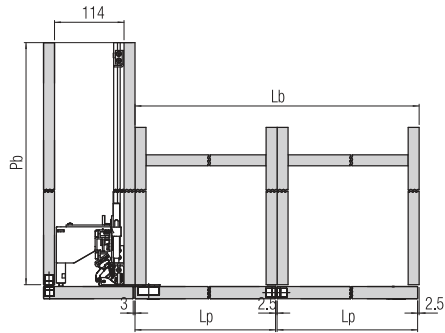

* Reversible system

Hp= Panel Height (1990-2200 / 2200-2700 mm)

Sp= Panel thickness (19-30 mm)

Lp= Panel Width

Pb= Panel Depth

Lb= Box Width

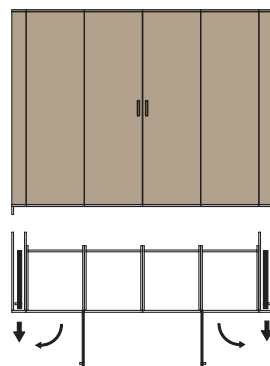
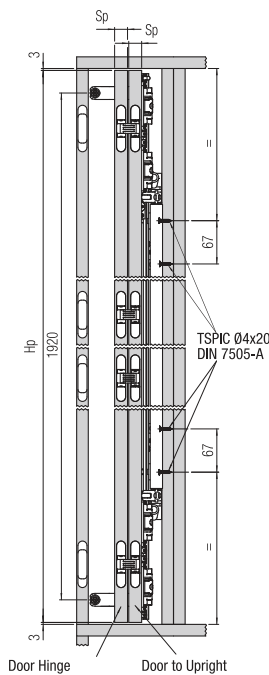

Door Hinges

Door to the Upright

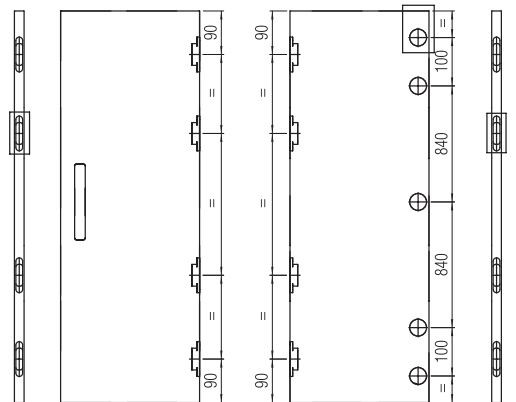

A=9 / Sp=18 mm
A=10 / Sp>20 mm

